

## Threaded or weld-in thermowell (fabricated) Models SWT52G, SWT52S, SWT71G, SWT71S

### Applications

- Wide range of applications in vessel, tubing and apparatus construction, machine building and industrial heating
- For use with models 52 and 73 mechanical thermometers

### Special features

- Cost-effective design
- Quick adjustability and replaceability of thermometers

### Description

Each thermowell is an important component of any temperature measurement point. It is used to separate the process from the surrounding area, thus protecting the environment and operating personnel and keeps aggressive media, high pressures and flow rates from the temperature sensor itself and thereby enables the thermometer to be exchanged during operation.

Based on the almost limitless application possibilities, there are a large number of variants, such as thermowell designs or materials. The type of process connection and the basic method of manufacture are important design differentiation criteria. A basic differentiation can be made between threaded and weld-in thermowells, and those with flange connections.



**Fig. left: Thermowell with thread**

**Fig. right: Thermowell with welding stud**

Furthermore, one can differentiate between fabricated and solid-machined thermowells. Fabricated thermowells are constructed from a tube, that is closed at the tip by a welded solid tip. Solid-machined thermowells are manufactured from barstock.

The SWTxx series of fabricated <sup>1)</sup> threaded or weld-in thermowells are specifically adapted for use with the models 52 and 73 mechanical thermometers.

Due to the cost-effective design and fast adjustment and exchange of the thermometer, these are the thermowells of choice for use in machine building and heating technology.

1) For short insertion lengths (copper alloy) solid-machined version optionally

## Standard version

### Thermowell material process connection

Copper alloy, St35<sup>1)</sup> or stainless steel

### Process connection

Models SWT52G, SWT71G: G ½ B thread

Models SWT52S, SWT71S: welding stud

### Connection to thermometer

Suitable for thermometers with smooth connection (without threads), collar Ø 18 mm;

Fixing via M4 retaining screw

### Bore size

Suitable for 8 mm insertion diameter (model 52 thermometer) or 13 mm (model 73 thermometer)

### Max. process temperature, process pressure

160 °C with copper alloy as thermowell material (6 bar stat.)

500 °C with St35, stainless steel as thermowell material (25 bar stat.)

Depending on

- Thermowell design
  - Dimensions
  - Material
- Process conditions
  - Flow rate
  - Density of medium

1) Thermowell stem material: stainless steel

### Insertion length

Suitable for the various standard insertion lengths,  $l_1$ , of models 52 and 73 thermometers

## Dimensions in mm

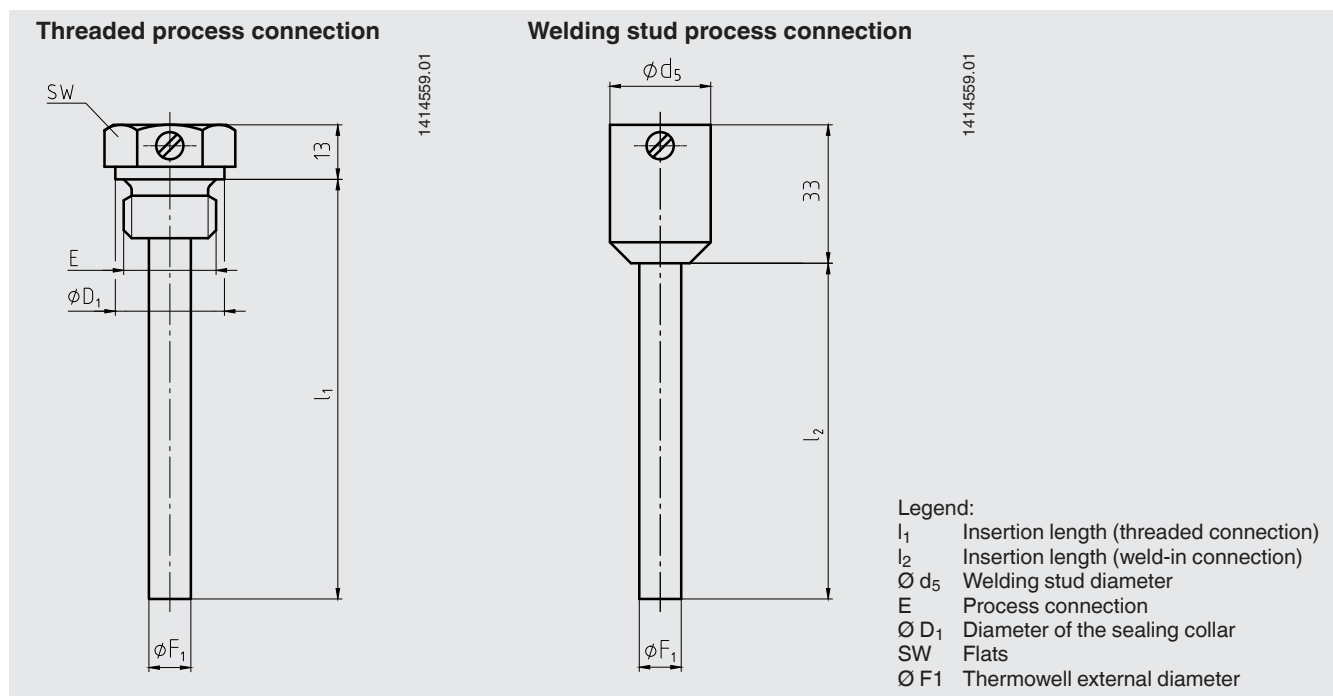

**Threaded process connection**

(Copper alloy, St35 or stainless steel)

Thermometer	Dimensions in mm				
	$l_1$	E	SW	$\varnothing F_1$	$\varnothing D_1$
Model 52	45	G ½ B	27	10	26
	63	G ½ B	27	10	26
	100	G ½ B	27	10	26
	160	G ½ B	27	10	26
	200	G ½ B	27	10	26
Model 73	63	G ½ B	27	16	26
	100	G ½ B	27	16	26
	160	G ½ B	27	16	26
	200	G ½ B	27	16	26

**Welding stud process connection**

(St35 or stainless steel)

Thermometer	Dimensions in mm		
	$l_2$	$\varnothing d_5$	$\varnothing F_1$
Model 52	43	24	10
	80	24	10
	140	24	10
	180	24	10
Model 73	43	24	16
	80	24	16
	140	24	16
	180	24	16

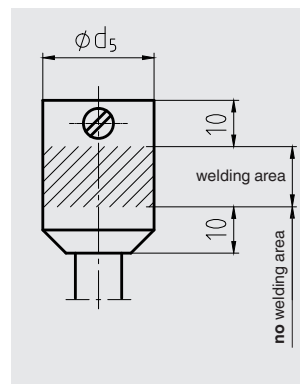
**Suitable for insertion lengths of models 52 and 73 thermometers**

Process connection	Insertion length, $l_1$ , of the thermometer
Thread	$l_1$ = insertion length, $l_1$ , of the thermowell
Welding stud	$l_1$ = insertion length, $l_2$ , of the thermowell + 20 mm [0.8 in]